

EXISTING ZONING

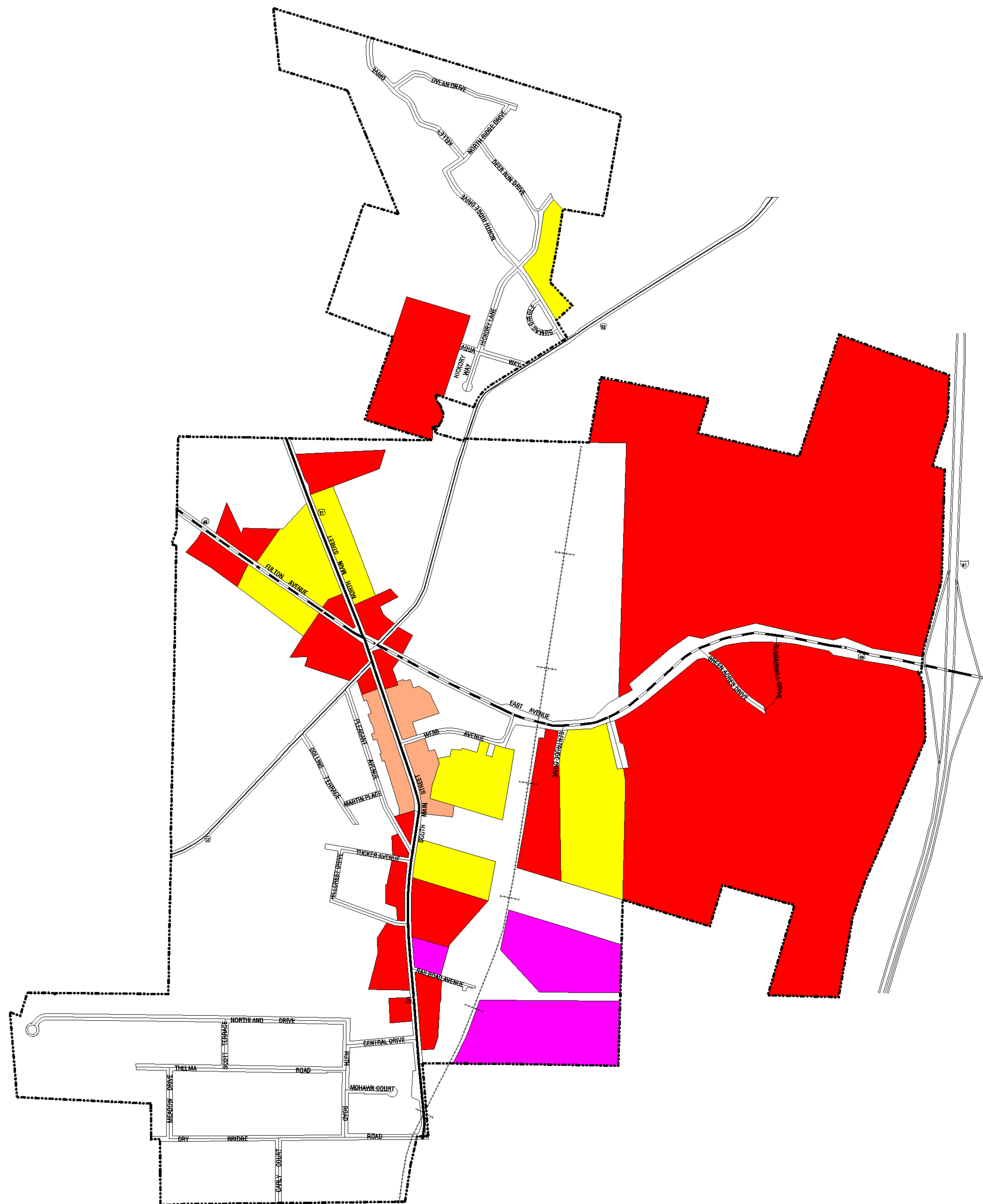

- R RESIDENTIAL
- RM MULTI-RESIDENTIAL
- RB RESIDENTIAL-BUSINESS
- C COMMERCIAL
- I INDUSTRIAL

- LOCAL ROADS
- COUNTY ROADS
- STATE ROADS
- U.S. 11
- INTERSTATE 81
- RAILROAD



PREPARED BY OSWEGO COUNTY DEPT. OF
PLANNING AND COMMUNITY DEVELOPMENT
DATE: JANUARY 2004

VILLAGE OF CENTRAL SQUARE ZONING LAW

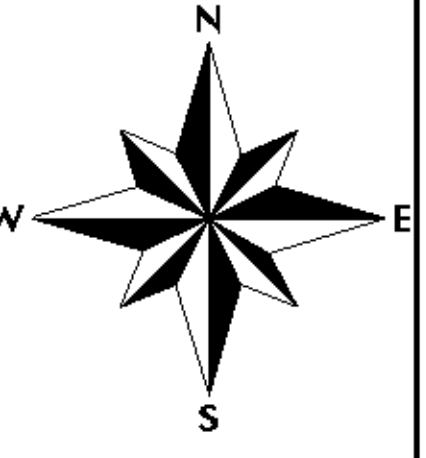
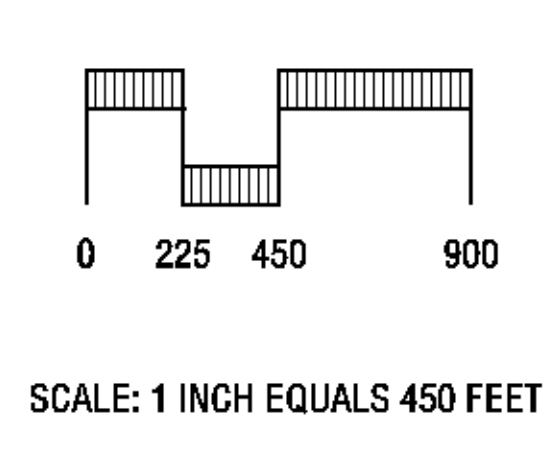

SOURCE: OSWEGO COUNTY DEPARTMENT OF REAL PROPERTY
TAX, 2004; VILLAGE OF CENTRAL SQUARE ZONING LAW, 2004

REVISIONS: